

Ultra High Vacuum Components

ISOLATORS

真空用の規格フランジに合わせた絶縁フランジです。
標準寸法の他、ご希望の電圧、用途に合わせたものが製造可能です。

Isolator flanges for vacuum application.
Standard sizes and custom made are available.

unit : mm

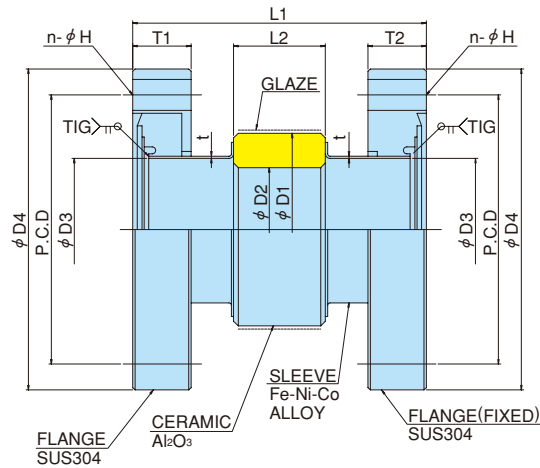

参考値：沿面耐電圧 DC600V/mm
AC400V/mm

No	PART NAME・(品名)	Part Number
A	ISOLATORS No.A	90283-1
B	ISOLATORS No.B	90283-2
C	ISOLATORS No.C	90283-3
D	ISOLATORS No.D	90283-4
E	ISOLATORS No.E	90283-5
F	ISOLATORS No.F	90283-6
G	ISOLATORS No.G	90283-7
H	ISOLATORS No.H	90283-8
I	ISOLATORS No.I	90283-9
J	ISOLATORS No.J	90283-10
K	ISOLATORS No.K	90283-11
L	ISOLATORS No.L	90283-12

No	φD1	φD2	φD3	φD4	L1	L2	T1	T2	P.C.D	φH	n	t
A	25	14	15.4	34	60	10	7.5	7.5	27	4.5	6	0.5
B	25	14	15.4	34	70	20	7.5	7.5	27	4.5	6	0.5
C	42	27	29	70	62	20	12.7	12.7	58.7	6.7	6	0.5
D	42	27	29	70	82	40	12.7	12.7	58.7	6.7	6	0.5
E	70	56	58.5	114	80	20	19	17.5	92.2	8.4	8	0.5
F	70	56	58.5	114	100	40	19	17.5	92.2	8.4	8	0.5
G	100	75	76.5	152	95	20	21	20	130.3	8.4	16	0.75
H	100	75	76.5	152	115	40	21	20	130.3	8.4	16	0.75
I	148	122	101.5	203	105	20	24	22	181.1	8.4	20	0.75
J	148	122	101.5	203	125	40	24	22	181.1	8.4	20	0.75
K	190	135	136	253	110	20	25	25	231.9	8.4	24	1.0
L	190	135	136	253	130	40	25	25	231.9	8.4	24	1.0

Ultra High Vacuum Components

ISOLATORS WITH BELLOWS

真空用の規格フランジに合わせた絶縁フランジです。
標準寸法の外、ご希望の電圧、用途に合わせたものが製造可能です。

Isolator flanges for vacuum application.
Standard sizes and custom made are available.

unit : mm

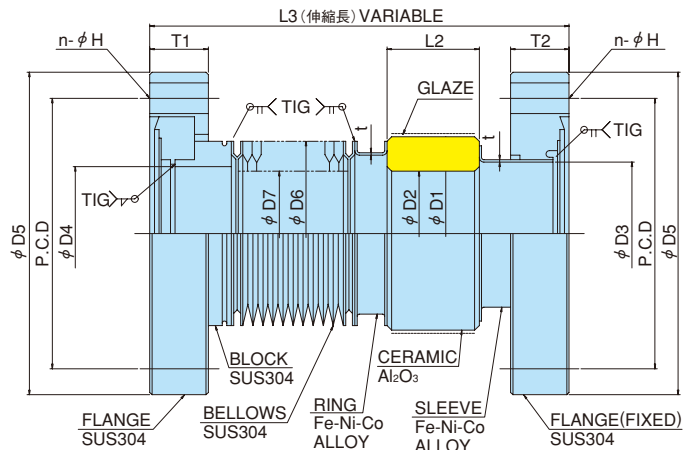

参考値：沿面耐電圧 DC600V/mm
AC400V/mm

No	PART NAME・(品名)	Part Number	No	T1	T2	P.C.D	H	n	t
A	ISOLATORS WITH BELLOWS No.A	90284-1	A	7.5	7.5	27	4.5	6	0.5
B	ISOLATORS WITH BELLOWS No.B	90284-2	B	7.5	7.5	27	4.5	6	0.5
C	ISOLATORS WITH BELLOWS No.C	90284-3	C	12.7	12.7	58.7	6.7	6	0.5
D	ISOLATORS WITH BELLOWS No.D	90284-4	D	12.7	12.7	58.7	6.7	6	0.5
E	ISOLATORS WITH BELLOWS No.E	90284-5	E	19	17.5	92.2	8.4	8	0.5
F	ISOLATORS WITH BELLOWS No.F	90284-6	F	19	17.5	92.2	8.4	8	0.5
G	ISOLATORS WITH BELLOWS No.G	90284-7	G	21	20	130.3	8.4	16	0.75
H	ISOLATORS WITH BELLOWS No.H	90284-8	H	21	20	130.3	8.4	16	0.75
I	ISOLATORS WITH BELLOWS No.I	90284-9	I	24	22	181.1	8.4	20	0.75
J	ISOLATORS WITH BELLOWS No.J	90284-10	J	24	22	181.1	8.4	20	0.75
K	ISOLATORS WITH BELLOWS No.K	90284-11	K	25	25	231.9	8.4	24	1.0
L	ISOLATORS WITH BELLOWS No.L	90284-12	L	25	25	231.9	8.4	24	1.0

No	φD1	φD2	φD3	φD4	φD5	φD6	φD7	L2	L3
A	25	14	15.4	14	34	26	12	10	63~71
B	25	14	15.4	14	34	26	12	20	71~79
C	42	27	29	31	70	40	27	20	88.5~96.5
D	42	27	29	31	70	40	27	40	108.5~116.5
E	70	56	58.5	60.5	114	80	60	20	100.5~108.5
F	70	56	58.5	60.5	114	80	60	40	120.5~128.5
G	100	75	76.5	79.5	152	100	75	20	105.5~113.5
H	100	75	76.5	79.5	152	100	75	40	125.5~133.5
I	148	122	101.5	104.5	203	162	132	20	118~126
J	148	122	101.5	104.5	203	162	132	40	138~147
K	190	135	136	140	253	185	135	20	117~125
L	190	135	136	140	253	185	135	40	137~145

No. A, B, E, F
は内側からボルトが
入りません。
ナットの使用のみと
なります。

No. A, B, E, F
apply Only nut not
bolt from inside.

Ultra High Vacuum Components

SAPPHIRE WINDOWS

単結晶サファイアを使った覗き窓です。真空用の規格フランジに合わせたサイズの他、耐圧用の窓の製作も行います。光学用の計測窓には、無反射コーティングを行うこともできます。

Single crystal sapphire is used. AR coating is option.

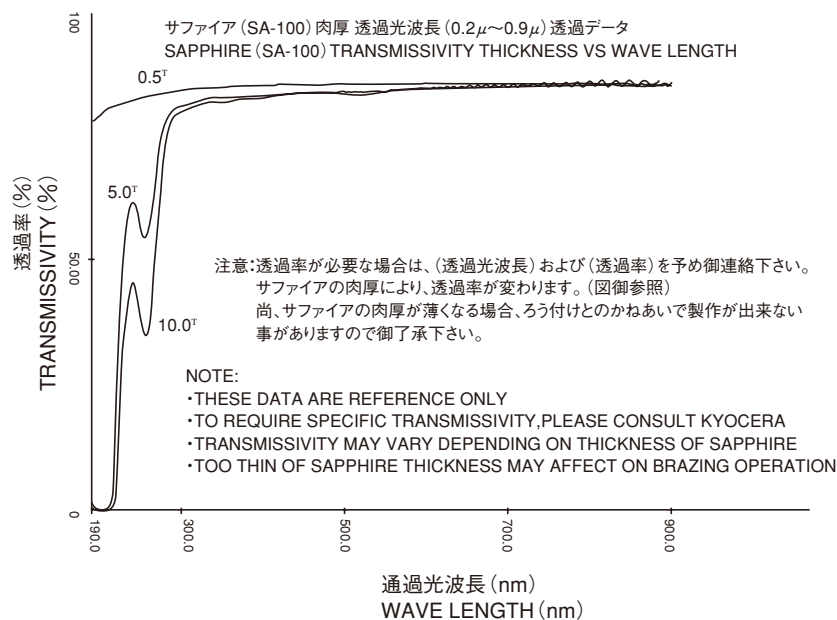
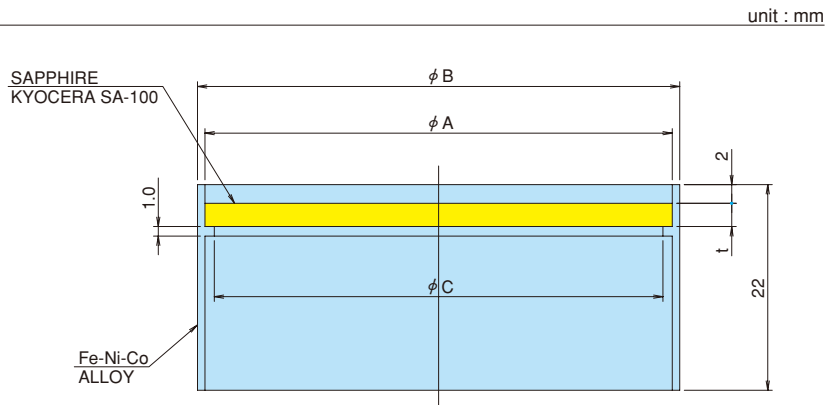

Part Number	PART NAME (φ) mm・名称	A	B	C	t
90167-1	SAPPHIRE WINDOWS φ20	20	21.6	18	2
90167-2	SAPPHIRE WINDOWS φ30	30	31.6	28	2
90167-3	SAPPHIRE WINDOWS φ35	35	36.6	33	2.5
90167-4	SAPPHIRE WINDOWS φ40	40	41.6	38	2.5
90167-5	SAPPHIRE WINDOWS φ50	50	51.6	48	2.5
90167-6	SAPPHIRE WINDOWS φ60	60	61.6	58	3
90167-7	SAPPHIRE WINDOWS φ70	70	71.6	68	3
90167-8	SAPPHIRE WINDOWS φ80	80	81.6	78	3
90167-9	SAPPHIRE WINDOWS φ100	100	101.6	98	4
90167-10	SAPPHIRE WINDOWS φ150	150	151.6	148	4

Ultra High Vacuum Components

SAPPHIRE WINDOWS WITH VACUUM FLANGE

真空用フランジ(コンフラットフランジ)にサファイア窓を取りつけたものです。真空装置にそのまま取り付けて使用して頂けます。

Products for vacuum flange assembled with sapphire windows. They can be used by attaching directly to vacuum equipment.

unit : mm

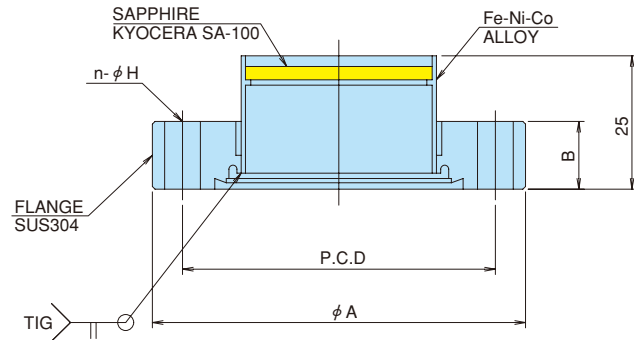

Part Number	PART NAME・名称	A	B	n	H	P.C.D
90170-1	70F SW35	70	12.7	6	6.7	58.7
90170-2	114F SW70	114	17.5	8	8.4	92.2
90170-3	152F SW100	152	20	16	8.4	130.3
90170-4	203F SW150	203	22	20	8.4	181.1

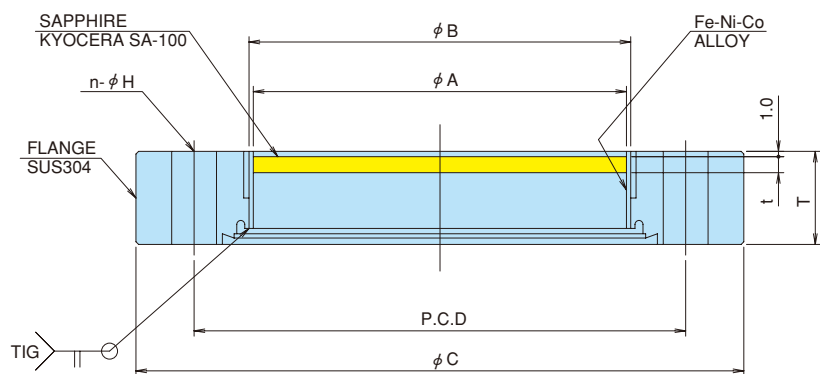

Part Number	PART NAME・名称	A	B	C	t	T	n	H	P.C.D
97111	70F SW35S	35	36.6	70	2.5	12.7	6	6.7	58.7
90173-1	114F SW70S	70	71.6	114	3	17.5	8	8.4	92.2
90173-2	152F SW100S	100	101.6	152	4	20	16	8.4	130.3
90173-3	203F SW150S	150	151.6	203	4	22	20	8.4	181.1